

Technical sheet :

# **MT 733 EASY**

---



 **MANITOU**  
HANDLING YOUR WORLD

Capacities		Metric
Max. capacity		3300 kg
Max. lifting height		6.90 m
Max. outreach		3.90 m
Breakout force with bucket		5770 daN
Weight and dimensions		
Overall length to carriage	l11	4.74 m
Length to face of forks	l2	4.74 m
Overall width	b1	2.33 m
Overall height	h17	2.30 m
Wheelbase	y	2.81 m
Ground clearance	m4	0.45 m
Overall cab width	b4	0.89 m
Tilt-up angle	a4	12 °
Tilt-down angle	a5	114 °
External turning radius (over tyres)	Wa1	3.80 m
Unladen weight (with forks)		6700 kg
Overall weight		6700 kg
Tyres type		Inflatable
Standard tyres		Alliance 400/80 - 24 - 162A8
Forks length / width / section	l / e / s	1200 mm x 125 mm / 45 mm
Performances		
Lifting		8.30 s
Lowering		6 s
Extension		7.30 s
Retraction		4.50 s
Crowd		3.40 s
Dump		2.80 s
Engine		
Engine brand		Deutz
Engine norm		Stage V / Tier 4 final
Engine model		TD 3.6 L
Number of cylinders / Capacity of cylinders		4 - 3621 cm³
I.C. Engine power rating - Power (kW)		75 Hp / 55.40 kW
Max. torque / Engine rotation		340 Nm @ 1600 rpm
Drawbar pull (Laden)		8360 daN
Transmission		
Transmission type		Torque converter
Number of gears (forward / reverse)		4 / 4
Max. travel speed		24.90 km/h
Parking brake		Manual
Service brake		Oil-immersed multi-discs braking on front & rear axles
Axle Manufacturer		Dana
Hydraulics		
Hydraulic pump type		Gear pump
Hydraulic flow / Pressure		92.70 l/min-260 bar
Tank capacities		
Engine oil		10 l
Hydraulic oil		128 l
Fuel tank		120 l
Noise and vibration		
Noise at driving position (LpA)		79 dB
Noise to environment (LwA)		104 dB
Vibration on hands/arms		< 2.50 m/s²
Miscellaneous		
Steering wheels (front / rear)		2 / 2
Drive wheels (front / rear)		2 / 2
Safety / Safety cab homologation		Standard EN 15000 / Cabin ROPS - FOPS Level 2
Controls		JSM

### MT 733 Easy - Dimensional drawing

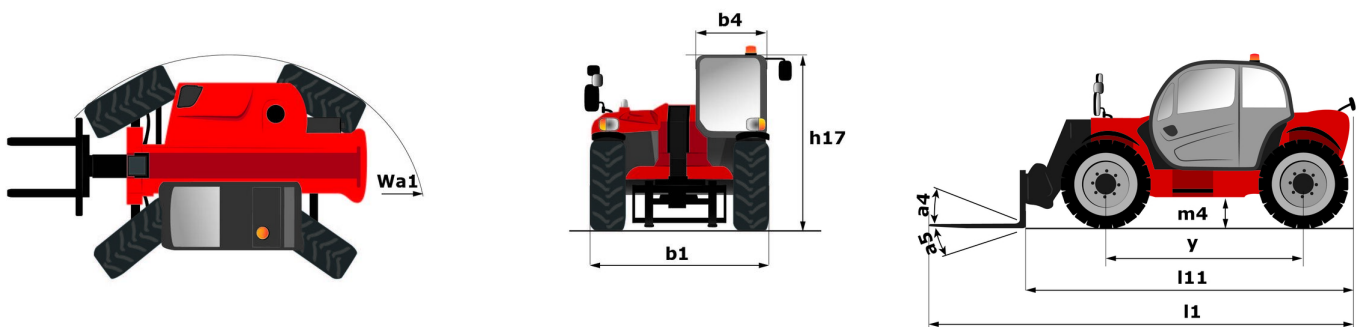

# MT 733 Easy - Load chart

Machine on tyres with forks Metric

